

 Digital Signage

LEVEL 9
Charging + Digital Displays

OUTDOOR ADVERTISING DISPLAY

65" outdoor advertising display - high brightness, mounted, tablet-style display ideal for any weather conditions

Designed for outdoor, 24/7 usage

Sunlight readable display with anti-reflective glass

IP65 rated for weather protection

IK10 rated to withstand tampering and damage

Integrated Android media player

Free lockable wall mount

ADDITIONAL FEATURES



Weatherproof design



Ambient light sensor



Giant tablet styling



Customisation available



Internal locker



Advanced temperature control system



Plug and play



Optional network upgrade

level9displays.com



Presenting the
Outdoor Advertising
Display range

LEVEL 9
Charging + Digital Displays



2,000 CD/M²
SUNLIGHT READABLE



IP65 RATED



IK10 RATED



GIANT TABLET STYLING

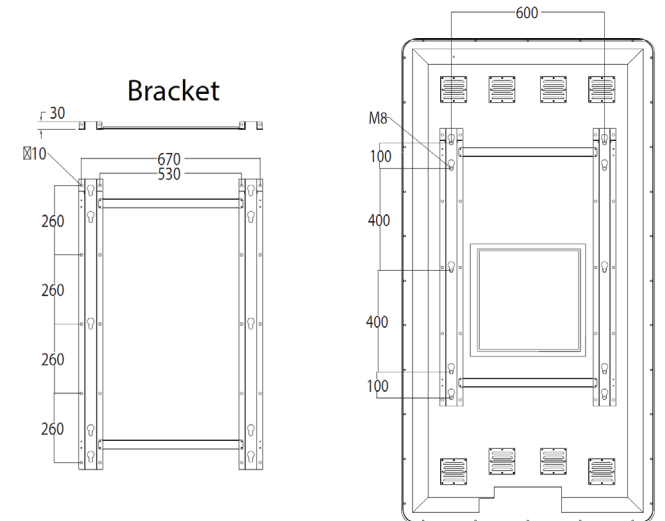
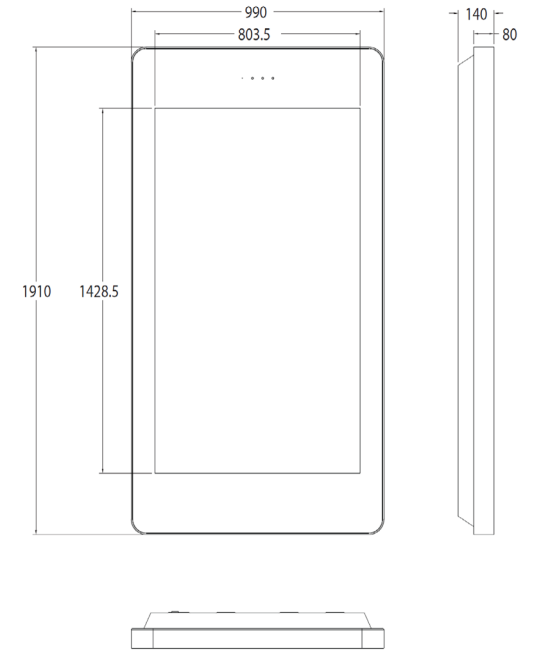

PLUG AND PLAY



OPTIONAL NETWORK UPGRADE



24/7 USAGE



LANDSCAPE OR PORTRAIT
ORIENTATION



65 Inch

Panel	Resolution	3840 x 2160
	Display Area (mm)	1428.5 x 803.5
	Aspect Ratio	16:9
	Brightness (cd/m ²)	2500
	Colour	16.7M
	Viewing Angle	178°
	Contrast Ratio	8000:1
AV Inputs	Video	HDMI, VGA
Power	Power Consumption (W)	550
	Input Voltage	AC110~240V (50Hz~60Hz)
Mechanical	Unit Size (WxHxD mm)	1910 x 990 x 140
	Package Size (WxHxD mm)	2060 x 1280 x 330
	Landscape VESA Holes (mm)	1100 x 400 / 1300 x 400
	Portrait VESA Holes (mm)	600 x 800 / 600 x 1000
	Net Weight (kg)	115
	Gross Weight (kg)	168
	IK Rating	IK10
Environmental	Operating Temperature	-20°C to 50°C
	Operating Humidity	10% to 80%
	Storage Temperature	-30°C to 60°C
	Storage Humidity	5% to 90%
	Enclosure Protection	IP65
Computer	Media Formats	Video (MPG, AVI, MP4, RM, RMVB, TS), Audio (MP3, WMA), Image (JPG, GIF, BMP, PNG)
	Media Resolution	1920 x 1080 / 1080 x 1920
	Internal Memory	6GB
	CPU	Quad-Core Cortex-A17@1.61GHz
	GPU	Mali-T760 MP4 @600MHz
	RAM	2GB DDR3
	Internal Storage	8GB NAND
	USB	USB2.0 HOST (x2)
	LAN	10/100/1000Mb/s Ethernet
	Wi-Fi	802.11b/g/n/ac
	OS	Android 5.1.1
	Graphic Engine	OpenGL ES 1.1/2.0/3.0/3.1, OpenCL 1.1, Renderscript, Direct3D 11.1
Accessories	Included	AC Power Cable, Remote Control, Wall Mount
	Optional	Touch Screen Upgrade, Network Upgrade, Camera
Warranty	Warranty Period	3 Year Warranty
	Technical Support	Lifetime

Why Level 9 Displays?

Level 9 Displays has partnered with Melford Technologies to bring you the latest next generation digital solutions.

Melford Technologies have been offering innovative technology solutions for over 50 years.

Together we provide experienced professional design, project planning, configuration, deployment, and maintenance services for a full one stop shop.

Contact Us

johnbaird@level9displays.com

(416) 931-3784

